



IAC Bottom Load Pleated Element

Do not be concerned if you do not have all the information requested, we will help you organize any additional information to provide a thorough and complete proposal.

Date

Name: Company: Address:

City: ST: Zip: Phone: Fax:

Email:

Dimensions:

A E

B F

C G

D

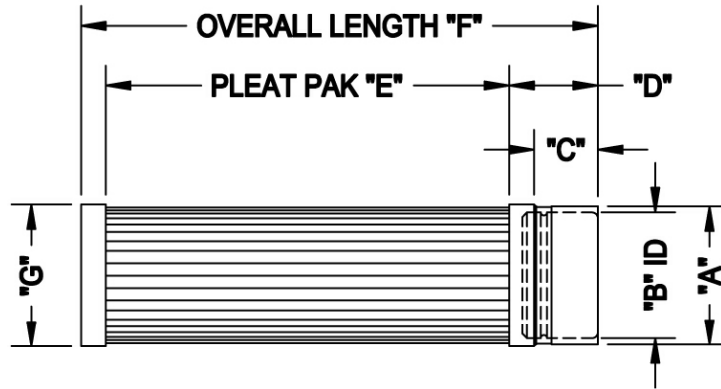

BOTTOM LOAD

Additional Information:

Quantity Required OEM of Dust Collector Operating Temperature

Number of Pleats Square Ft. Cloth per Element Media

Finish (if any) Top Construction (molded polyurethane or metal) Bottom Construction (molded polyurethane pan or metal pan)

Inner Core Construction (polypropylene or metal, if metal, stainless or galvanized)

Is this a new installation or a replacement of existing elements?

Plant ID No. (if available)

Thank you,
Industrial Accessories Company

Industrial Accessories Company
4800 Lamar Avenue
Mission, KS 66202
Ph: 1-800-334-7431
Fax: 913-384-6577
Email: iaccorp@iac-intl.com
Website: www.iac-intl.com